

## COMBINED FILTER-REGULATOR G<sup>1</sup>/<sub>4</sub> ~ G<sup>1</sup>/<sub>2</sub>

### Compressed Air

Construction	Body—Techno-polymer Bowl—Polyamide with Guard
Drain	Automatic & Semi-Automatic
Standard Filter	20 x 10 <sup>-3</sup> mm
Regulator Type	Relieving
Ambient Temperature	+5 ~ +50 °C
Working Pressure	0 ~ 16 bar
Set Pressure Range	0 ~ 8 bar
Mounting	Vertical



Connection	Part Number		Bowl Capacity cm <sup>3</sup>	Flow at 6 Bar NI/min	Weight kg
	Semi Auto	Auto			
G <sup>1</sup> / <sub>4</sub>	TA000041	TA000117	22	720	0.107
G <sup>3</sup> / <sub>8</sub>	TA000042	TA000044	42	1800	0.405
G <sup>1</sup> / <sub>2</sub>	TA000043	TA000048	100	2520	0.565

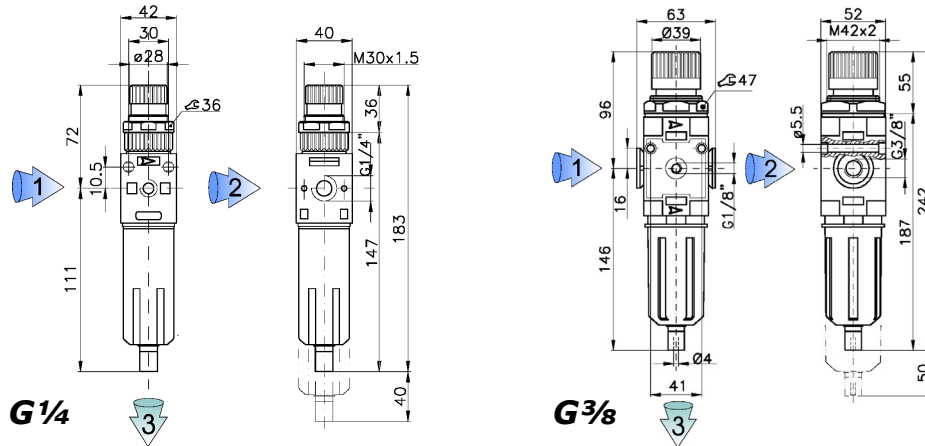

### Accessories

40mm Gauge 0—12 bar	TA000262
40mm Gauge 0—6 bar	TA000261
Mounting Bracket G <sup>1</sup> / <sub>4</sub>	TA000010
Mounting Bracket G <sup>3</sup> / <sub>8</sub> /G <sup>1</sup> / <sub>2</sub>	TA000160

### Spare Filter Elements

G <sup>1</sup> / <sub>4</sub>	AGT00022
G <sup>3</sup> / <sub>8</sub>	AGT00032
G <sup>1</sup> / <sub>2</sub>	AGT00029

