

PRESSURE REGULATOR G¹/₄ ~ G¹/₂

Compressed Air

Construction	Body—Techno-polymer
Type	Relieving
Ambient Temperature	+5 ~ +50 °C
Working Pressure	0 ~ 16 bar
Set Pressure Range	0—8 bar
Mounting	Vertical



Protected against over-pressurisation

Connection	Part Number	Flow at 6 Bar	Weight
Inches		NI/min	kg
G ¹ / ₄	TA000021	720	0.135
G ³ / ₈	TA000022	1800	0.325
G ¹ / ₂	TA000023	2520	0.435

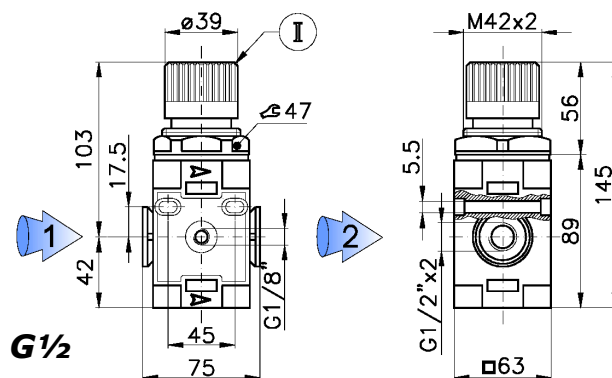
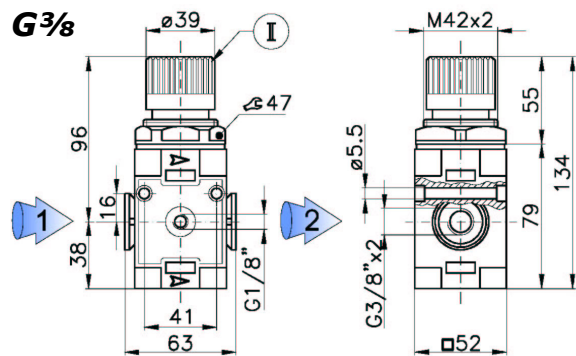
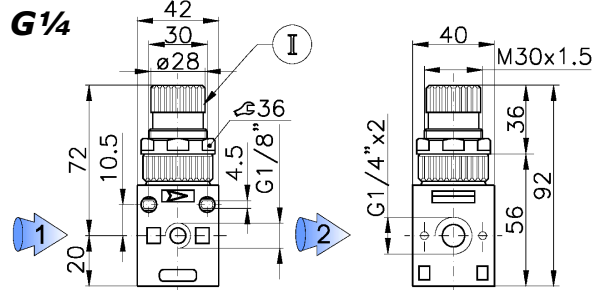

Accessories

40mm Gauge 0—12 bar	TA000262
40mm Gauge 0—6 bar	TA000261
Mounting Bracket G ¹ / ₄	TA000010
Mounting Bracket G ³ / ₈ /G ¹ / ₂	TA000160